

Trois types de projections sur un plan tangent à la sphère

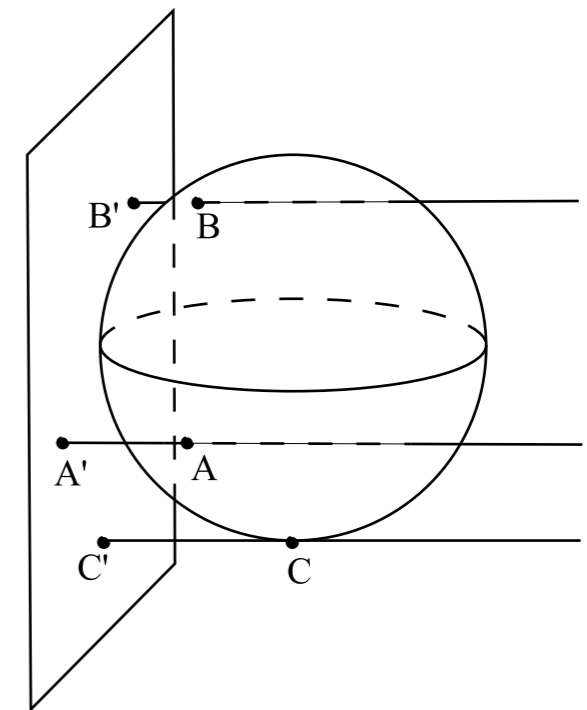
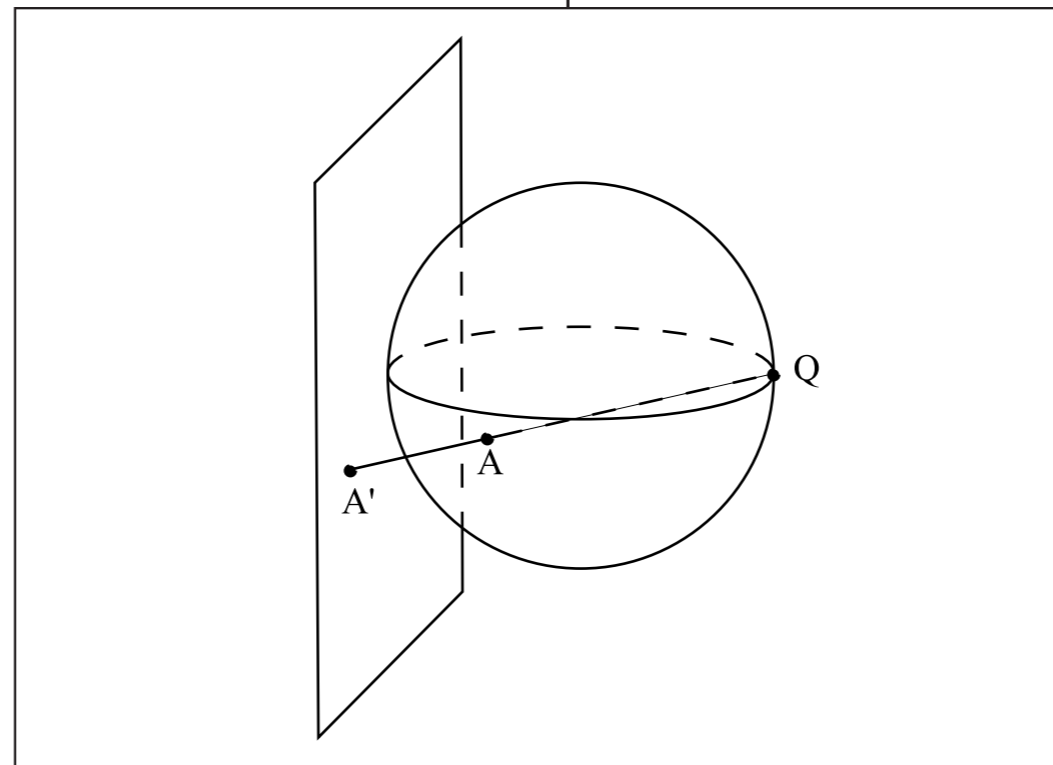
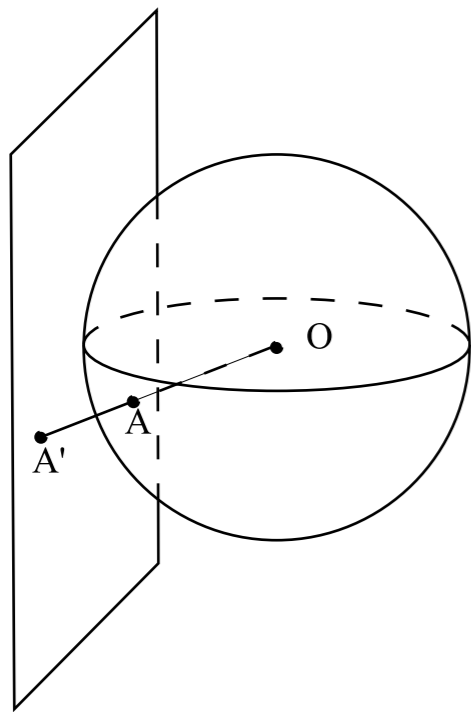

Projection
gnomonique

Projection
stéréographique

Projection
orthographique

Une projection **équivalente** préserve
les rapports d'aires

Une projection **conforme** préserve les
angles

Projection cylindrique de Lambert

Elle était déjà connue d'Archimède!

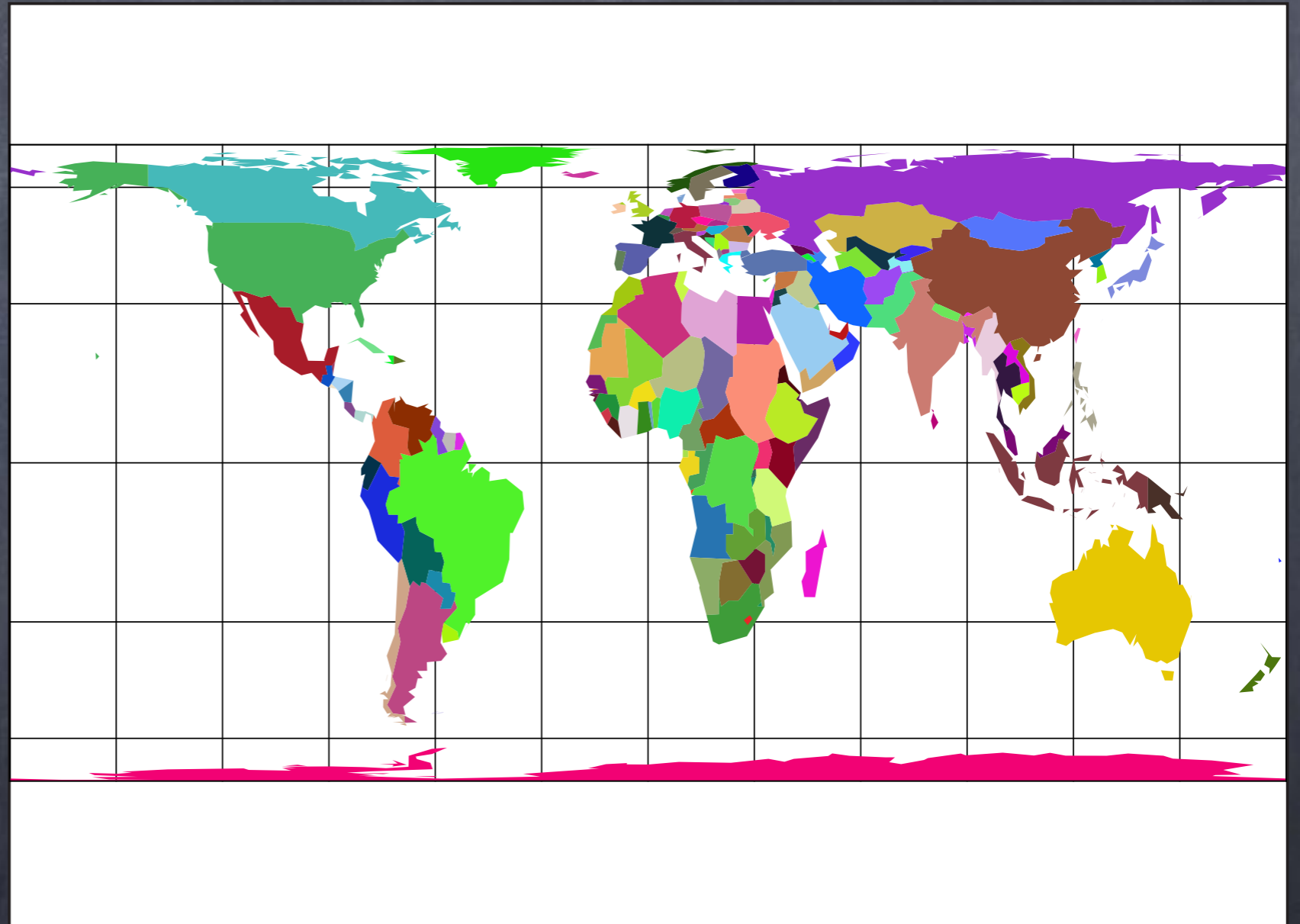
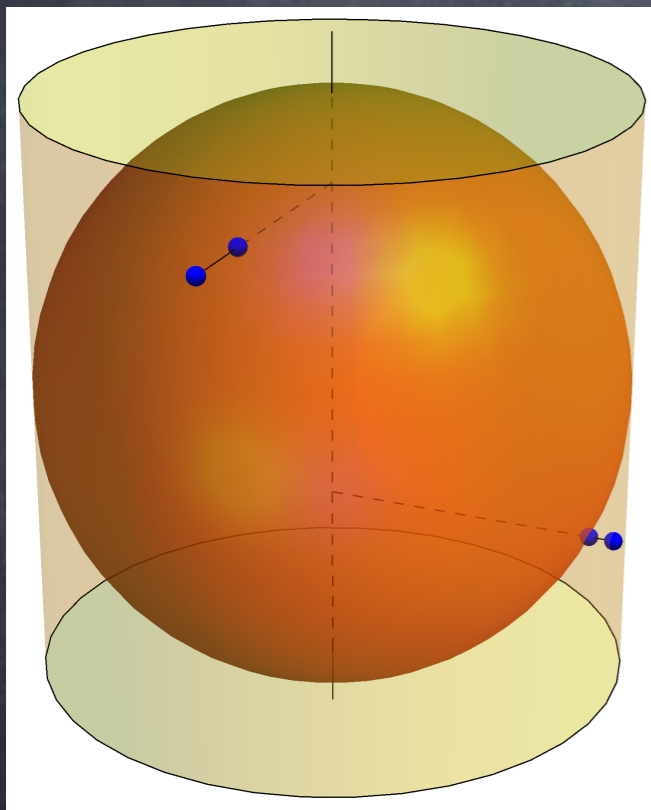

Elle est équivalente

Projection de Mercator (sur un cylindre infini!)

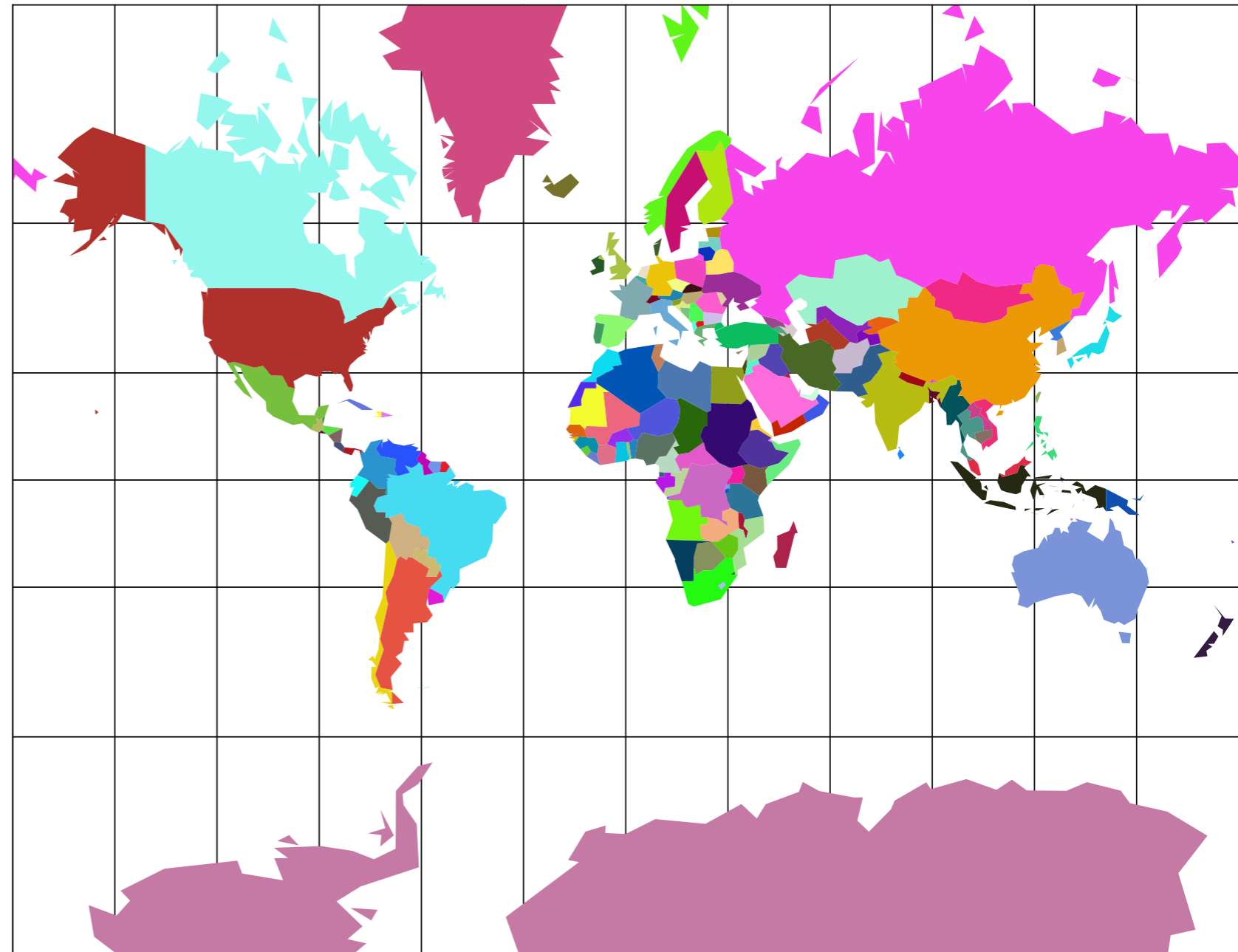
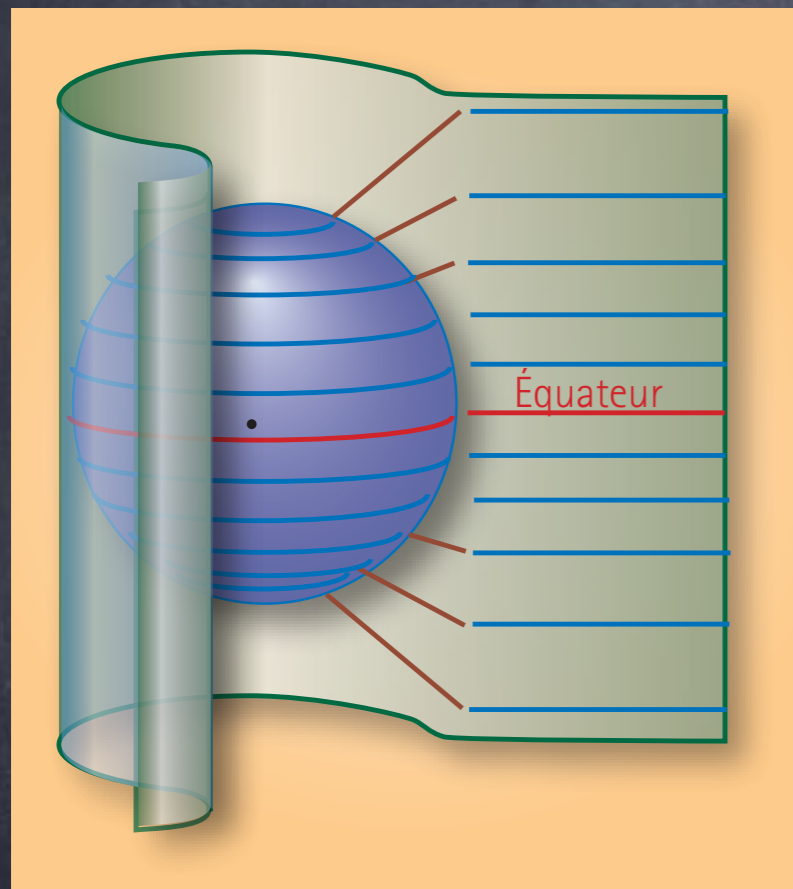

Elle est conforme

Projection stéréographique

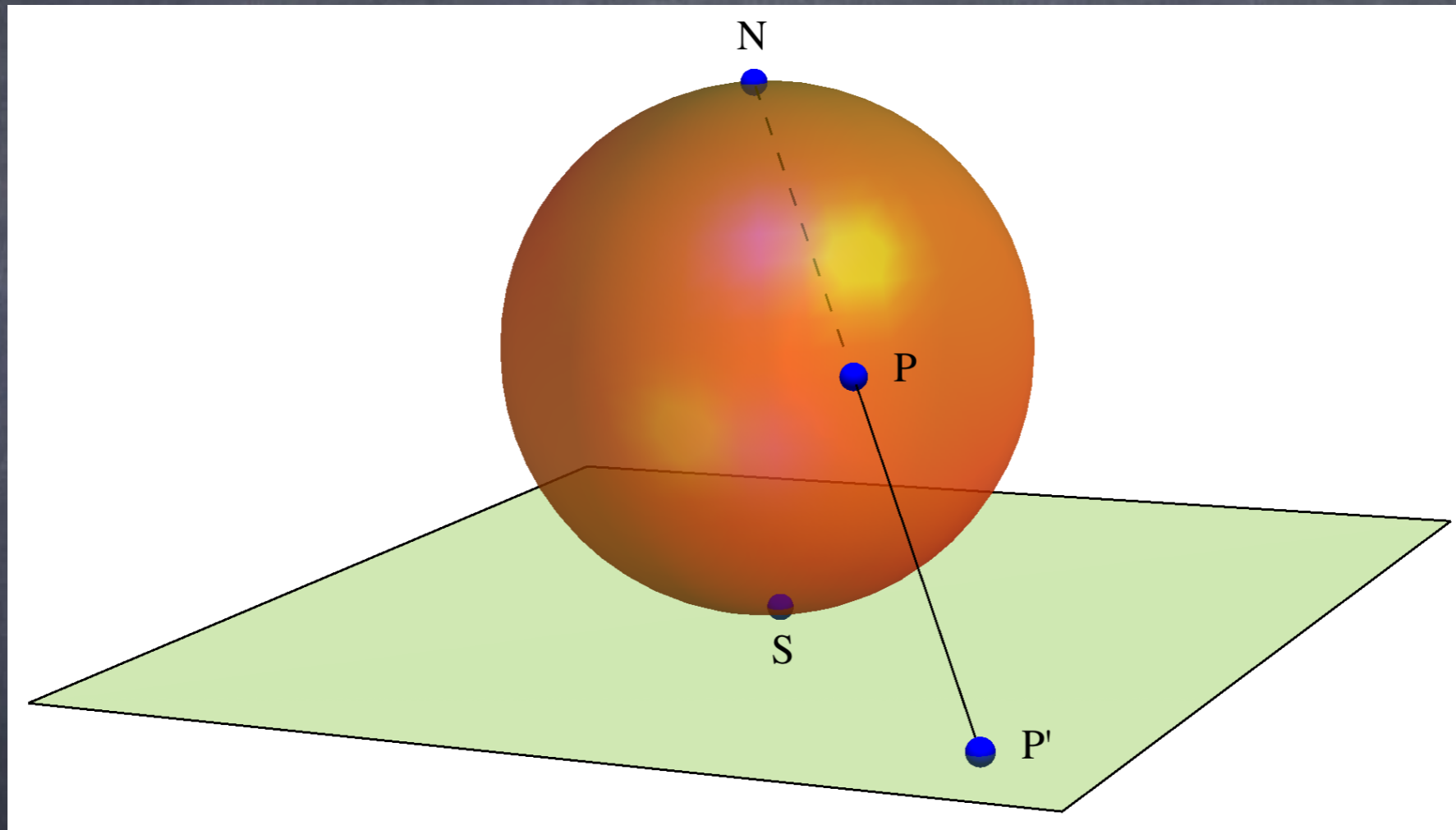

Elle est conforme

Projection de Lambert azimutale

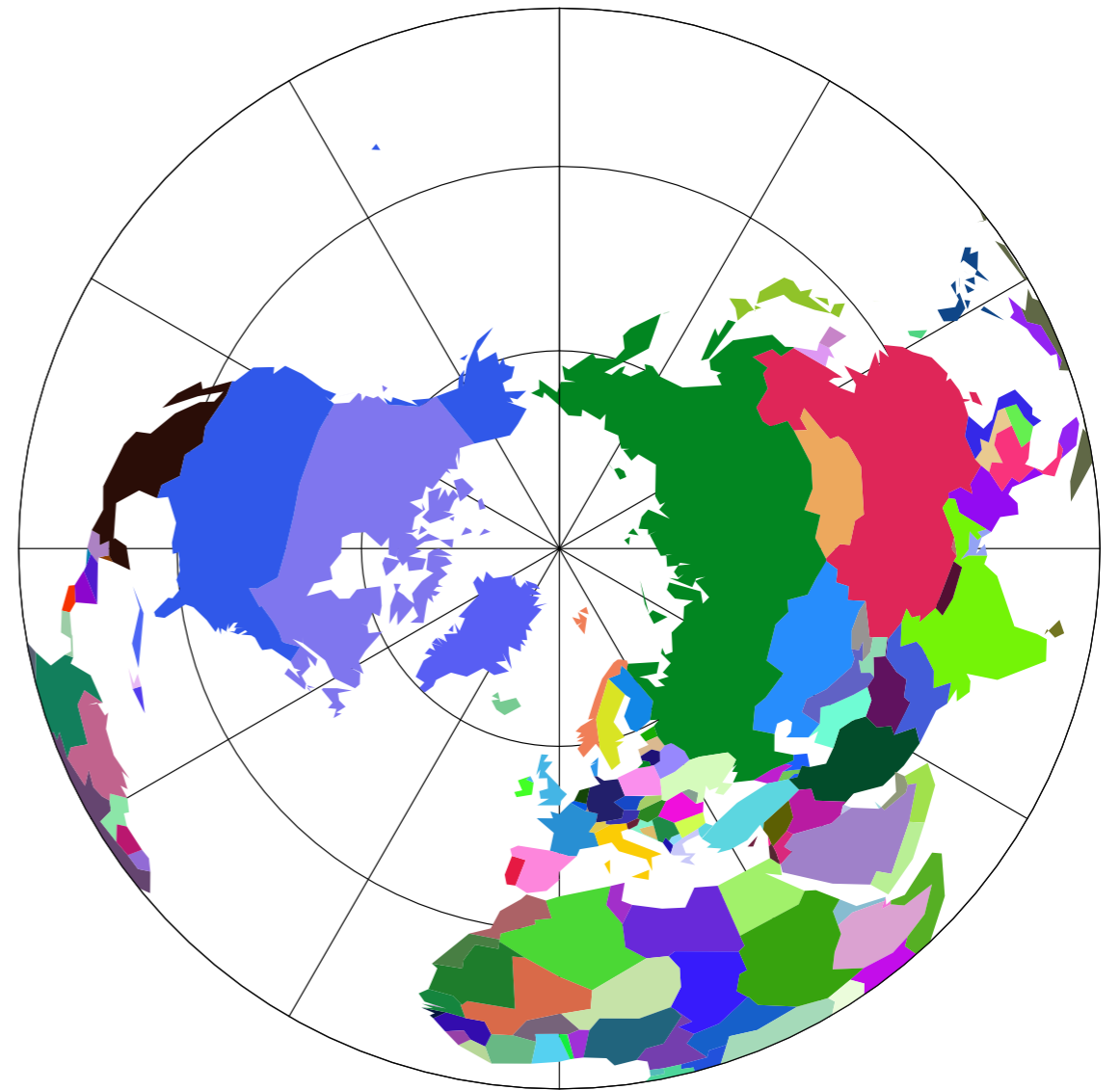
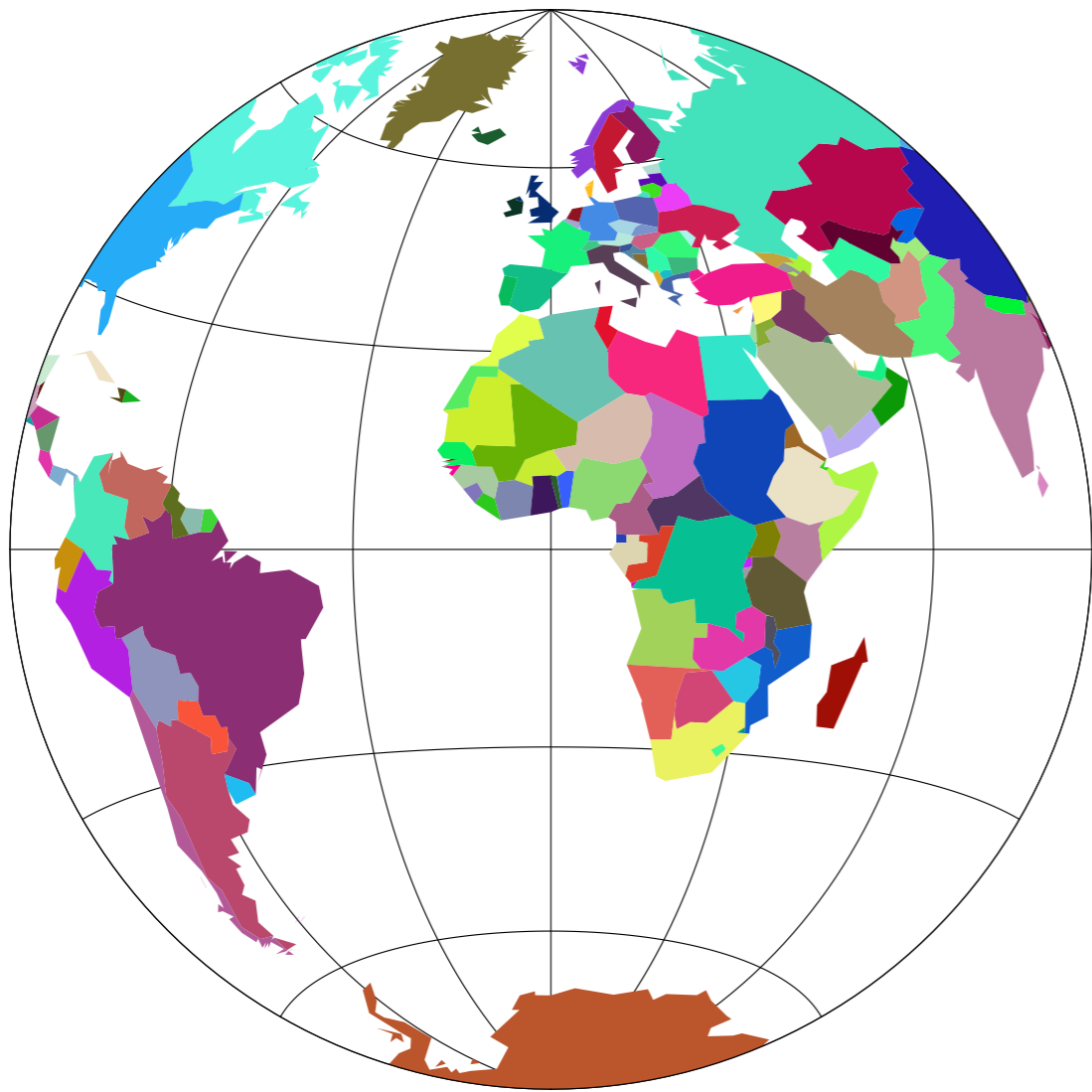

Elle est équivalente